

ISSUE/REVISION RECORD

DATE	DESCRIPTION
10/28/11	VILLAGE REVIEW
01/10/14	VILLAGE REVIEW
02/07/14	VILLAGE COMMENTS
05/12/14	REV. PER NEW BLDG.
05/29/14	BUILDING PERMIT
07/11/14	VILLAGE REVIEW
09/05/14	PLAN COMMISSION
10/07/14	BUILDING PERMIT
10/23/14	VILLAGE REVIEW

PROFESSIONAL SEAL

PROFESSIONAL SEAL

PROFESSIONAL IN CHARGE

D. BEHRENS, RLA

PROJECT MANAGER
J. COYLE

QUALITY CONTROL
D. BEHRENS

DRAWN BY
S. DREIER

PROJECT NAME

VLAND

**BOLINGBROOK,
ILLINOIS**

**SWQ WEBER ROAD
& BOUGHTON ROAD**

PROJECT NUMBER

20130893.0

SHEET TITLE

**LANDSCAPE
NOTES AND
DETAILS**

SHEET NUMBER

L2.0

NOT ISSUED FOR CONSTRUCTION

NOTES

LANDSCAPE PLANTING

THE LANDSCAPE CONTRACTOR SHALL FAMILIARIZE HIMSELF WITH THE SITE CONDITIONS AND VERIFY THEM TO HIS SATISFACTION. THE LANDSCAPE CONTRACTOR SHALL ACCEPT THE SITE CONDITIONS AND DO THE WORK SPECIFIED WITHOUT ADDITIONAL COMPENSATION FOR POSSIBLE VARIATION FROM GRADES AND CONDITIONS SHOWN.

PRIOR TO CONSTRUCTION THE LANDSCAPE CONTRACTOR SHALL BE RESPONSIBLE FOR LOCATING ALL UNDERGROUND UTILITIES AND SHALL AVOID DAMAGE TO ALL UTILITIES DURING CONSTRUCTION. SHOULD THE LANDSCAPE CONTRACTOR CAUSE DAMAGE TO ANY UTILITIES HE SHALL MAKE NECESSARY REPAIRS AS QUICKLY AS POSSIBLE WITHOUT ADDITIONAL COMPENSATION.

ALL PLANT MATERIAL SIZES AND MEASUREMENTS, INCLUDING TRUNK, HEAD, AND SPREAD SIZES, CONTAINER AND ROOTBALL SIZES, QUALITY AND CONDITION SHALL CONFORM TO THE STANDARDS SET FORTH IN THE CURRENT ISSUE OF "AMERICAN STANDARDS FOR NURSERY STOCK" (ANSI.Z60.1).

ALL PLANT MATERIAL ARE SUBJECT TO THE APPROVAL BY THE OWNER, AND MAY BE INSPECTED AT THE PLACE OF GROWTH OR ON SITE PRIOR TO PLANTING. LANDSCAPE ARCHITECT RETAINS THE RIGHT TO REJECT ANY PLANT MATERIAL WHICH IS NOT TO HIS SATISFACTION.

THE LANDSCAPE CONTRACTOR SHALL BE RESPONSIBLE FOR MAINTAINING, IN FULL, ALL LANDSCAPE PLANTING WORK (INCLUDING WATERING, SPRAYING FOR INSECTS AND DISEASE, MULCHING, MOWING, FERTILIZING, CULTIVATING, EDGING AND WEEDING) FOR A PERIOD OF 90 DAYS AFTER ACCEPTANCE BY THE OWNER.

THE LANDSCAPE CONTRACTOR SHALL COMPLETELY GUARANTEE ALL LANDSCAPE PLANTING WORK AND MATERIALS FOR A PERIOD OF ONE (1) FULL YEAR FROM THE DATE THE WORK HAS BEEN APPROVED BY THE OWNER AS INSTALLED. ALL PLANT MATERIAL NOT HEALTHY GROWING CONDITION SHALL BE REMOVED IMMEDIATELY AND REPLACED AS SOON AS POSSIBLE WITH LIKE KIND AND SIZE AT NO CHARGE TO THE OWNER.

THE LANDSCAPE CONTRACTOR SHALL BE RESPONSIBLE FOR OBTAINING SOIL SAMPLES FROM SOIL AND NATIVE OR FILL SOILS AT THE SITE AND SUBMITTING THEM TO AN APPROVED SOIL TESTING LABORATORY, AND OBTAIN ANALYSES AND RECOMMENDATIONS FOR AMENDING THESE SOILS AND FERTILIZATION OF SPECIFIED PLANT MATERIAL.

ALL PLANTING AREAS, SHRUB BEDS AND TREES SHALL BE MULCHED WITH A MINIMUM COMPACTED DEPTH OF FOUR (4) INCHES OF MULCH AS SPECIFIED. PRIOR TO MULCHING APPLY A PRE-EMERGENT HERBICIDE (APPROVED BY OWNER) AS RECOMMENDED BY THE MANUFACTURER, TO PREVENT RECURRING WEED AND GRASS GROWTH.

CONTRACTOR IS TO TAKE SPECIAL CARE WHEN INSTALLING NEW PLANT MATERIAL SO AS NOT TO DISTURB ANY EXISTING PLANTINGS DESIGNATED TO REMAIN. ANY EXISTING PLANT MATERIAL DAMAGED BY CONTRACTOR DURING CONSTRUCTION SHALL BE REPLACED WITH LIKE MATERIAL OF SIMILAR SPECIES AND SIZE AT THE CONTRACTOR'S EXPENSE AND NO ADDITIONAL COST TO OWNER.

TURF AND LAWNS

ALL DISTURBED AREAS SHALL RECEIVE 4" MINIMUM OF TOPSOIL (COMPACTED) AND GRASSED WITH SOD OR SEED AS INDICATED ON PLAN. LANDSCAPE CONTRACTOR TO COORDINATE HIS/HER WORK WITH OTHER TRADES REGARDING FINISH GRADING. IF AVAILABLE CONTRACTOR IS TO USE STOCKPILED TOPSOIL ONSITE. IF NOT AVAILABLE THE LANDSCAPE CONTRACTOR WILL BE RESPONSIBLE FOR IMPORTING THE TOPSOIL NECESSARY TO MEET FINISH GRADE.

TOPSOIL, SHALL BE FERTILE, FRIABLE AND REPRESENTATIVE OF LOCAL PRODUCTIVE SOIL, CAPABLE OF SUSTAINING VIGOROUS PLANT GROWTH AND FREE OF CLAY LUMPS, SUBSOIL, NOXIOUS WEEDS OR OTHER FOREIGN MATTER SUCH AS STONES, ROOTS, STICKS AND OTHER EXTRANEOUS MATERIALS: NOT FROZEN OR MUDDY. pH OF TOPSOIL TO RANGE BETWEEN 5.5 AND 7.5.

SODDED AREAS SHALL BE GRASSED KENTUCKY BLUEGRASS SOD. SOD SHALL BE LAID WITH CLOSE, TIGHT FITTING JOINTS, WHICH SHALL BE LAID IN ROWS PARALLEL TO THE CONTOUR LINES. ALL SODDED AREAS SHALL BE ROLLED TO ACHIEVE A SMOOTH, UNIFORM LAWN.

FERTILIZATION AND SOIL AMENDMENTS FOR ALL GRASSED AREAS SHALL BE AS PER LABORATORY ANALYSIS. HYDROSEEDING MAY BE SUBSTITUTED FOR MECHANICAL SEEDING BY MIXING SEED, FERTILIZER AND PULVERIZED MULCH IN WATER, USING EQUIPMENT SPECIFICALLY DESIGNED FOR HYDROSEED APPLICATION. MIX UNTIL UNIFORMLY BLENDED INTO HOMOGENEOUS SLURRY SUITABLE FOR HYDRAULIC APPLICATION. APPLY UNIFORMLY AT A RATE AS REQUIRED TO OBTAIN SPECIFIED SEEDING RATE.

ANY EXISTING LAWN AREA DISTURBED BY CONSTRUCTION IS TO BE REPAIRED TO ITS ORIGINAL CONDITION BY SODDING.

TREES AND SHRUBS

ALL TREES LOCATED IN GRASSED AREAS SHALL BE PLANTED AS PER DETAIL AND MULCHED WITH AT LEAST FOUR (4) FOOT DIAMETER OF SHREDDED BARK MULCH, TO A MINIMUM 3" DEPTH.

SHRUB BEDS SHALL BE MOUNDING WITH TOPSOIL A MINIMUM OF 6" ABOVE TOP OF CURB AND SHALL BE MULCHED WITH A 3" DEPTH OF SHREDDED BARK MULCH.

TREES SHALL BE PLANTED NO CLOSER THAN FIVE (5) FEET FROM BACK OF SIDEWALK OR BUILDING STRUCTURE.

LOCATION AND LAYOUT OF ALL SHRUBS AND TREES SHALL BE APPROVED BY LANDSCAPE ARCHITECT.

ALL TREE PROTECTION DEVICES ARE TO BE INSTALLED PRIOR TO START OF LAND DISTURBANCE AND MAINTAINED UNTIL FINAL LANDSCAPING IS INSTALLED.

ALL TREES ARE TO BE STAKED AND GUYED PER PLANTING DETAILS.

TREES AND SHRUBS SHALL NOT BE LOCATED CLOSER THAN TEN (10) FEET TO FIRE HYDRANTS, TRANSFORMERS OR OTHER ABOVE GROUND UTILITIES.

REVISIONS TO THE APPROVED LANDSCAPE PLAN REQUIRE THE WRITTEN APPROVAL OF THE PLANNING AND ZONING ADMINISTRATOR.

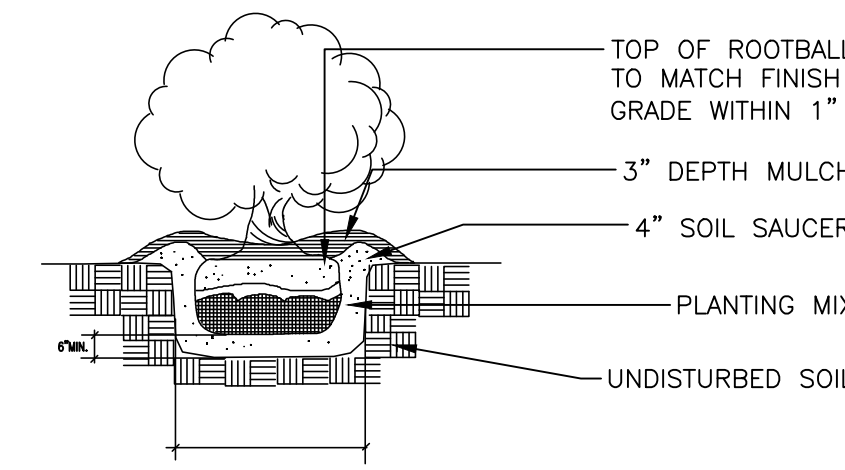

4 SHRUB PLANTING DETAIL
NOT TO SCALE 329333.16-01



****SEE PLAN FOR REQUIRED SPACING**

SPACING "D"	ROW WIDTH "A"	NO. OF PLANTS/SF
6" O.C.	5.20"	4.61
8" O.C.	6.93"	2.60
10" O.C.	8.66"	1.66
12" O.C.	10.44"	1.15
15" O.C.	13.00"	.738
18" O.C.	15.60"	.512
24" O.C.	20.80"	.350

5 GROUNDCOVER PLANTING DETAIL
NOT TO SCALE 329333.83-01

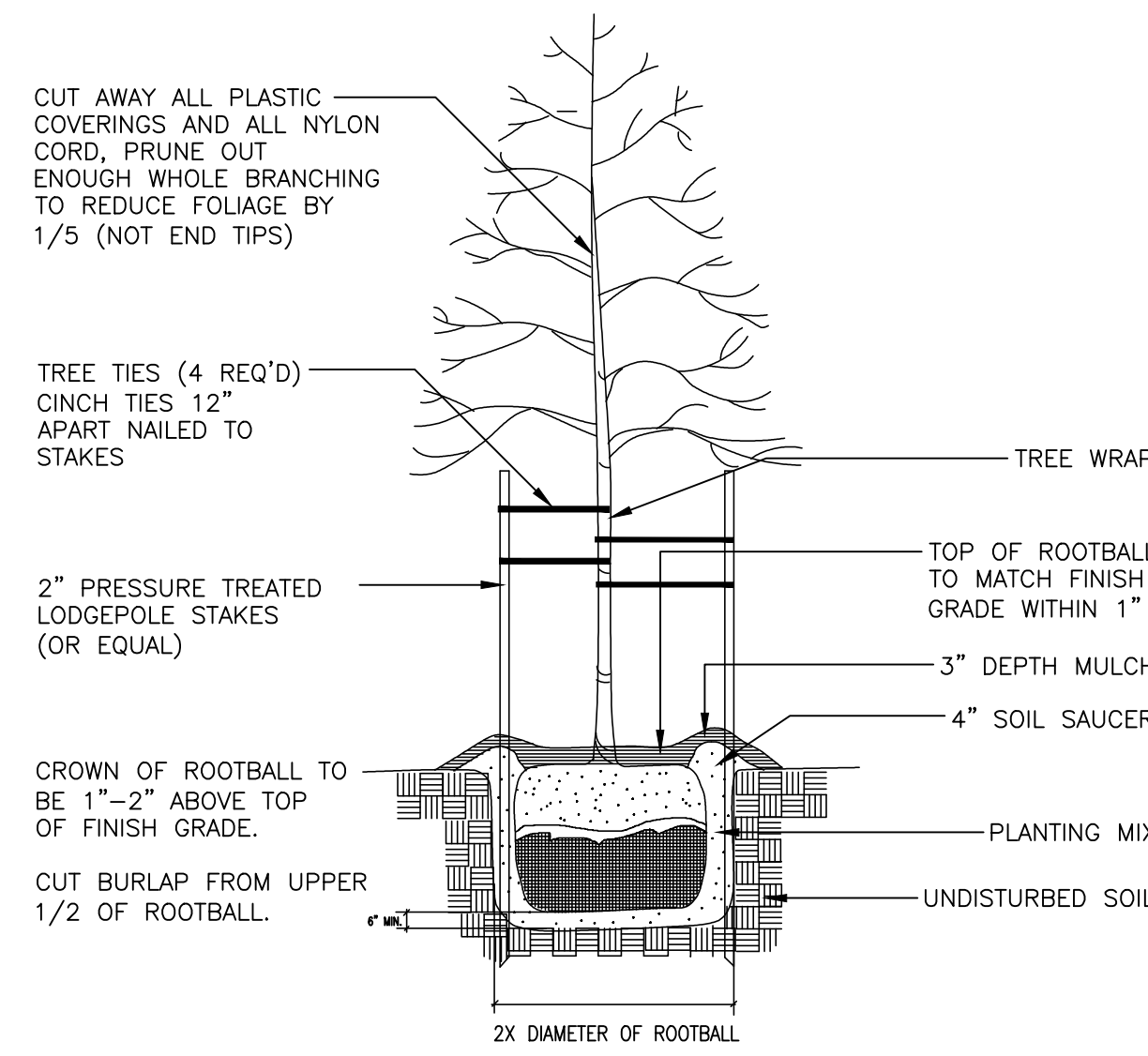

1 TREE PLANTING DETAIL
NOT TO SCALE 329343.39-01

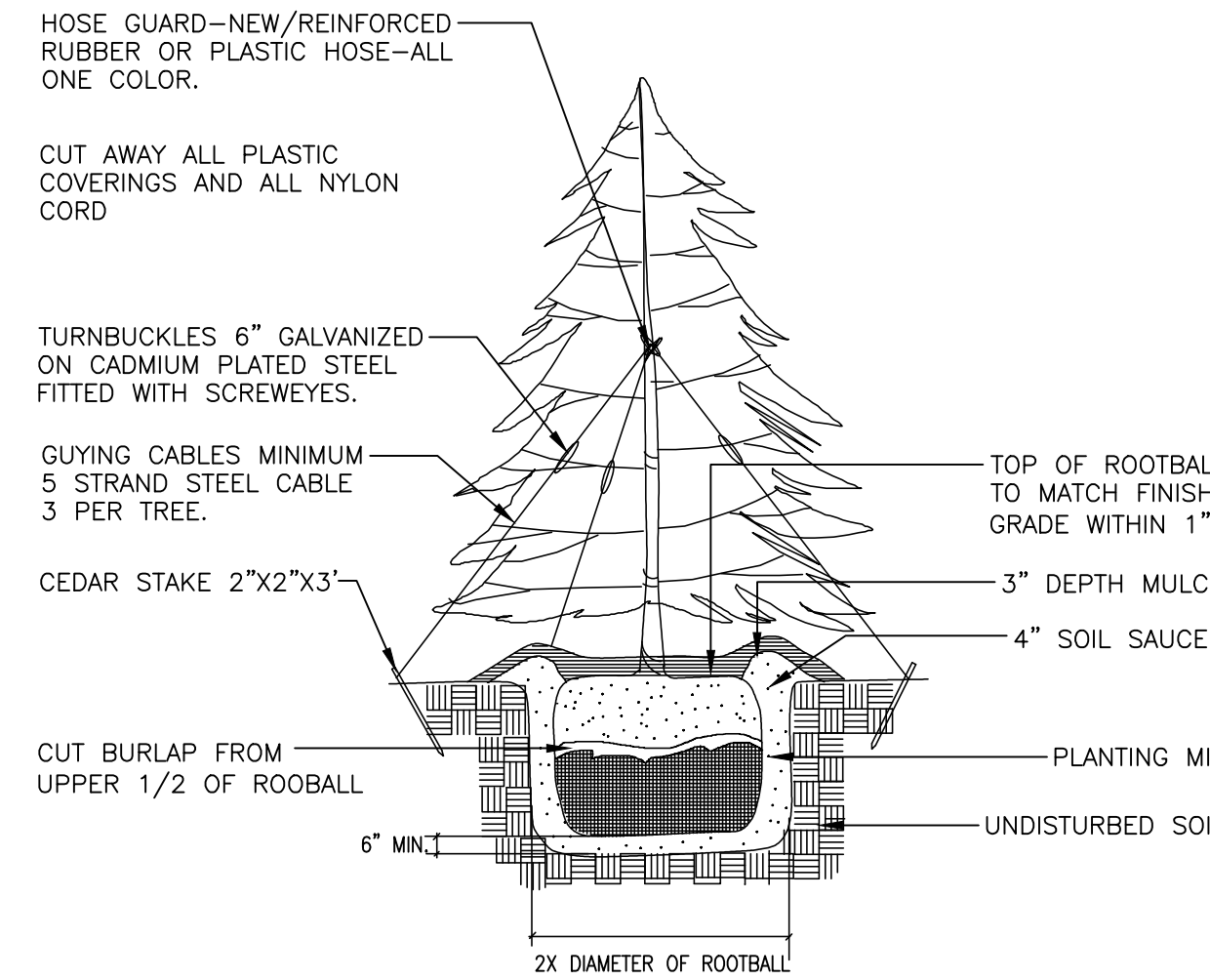

2 EVERGREEN TREE PLANTING DETAIL
1" = 1" 329343.46-01

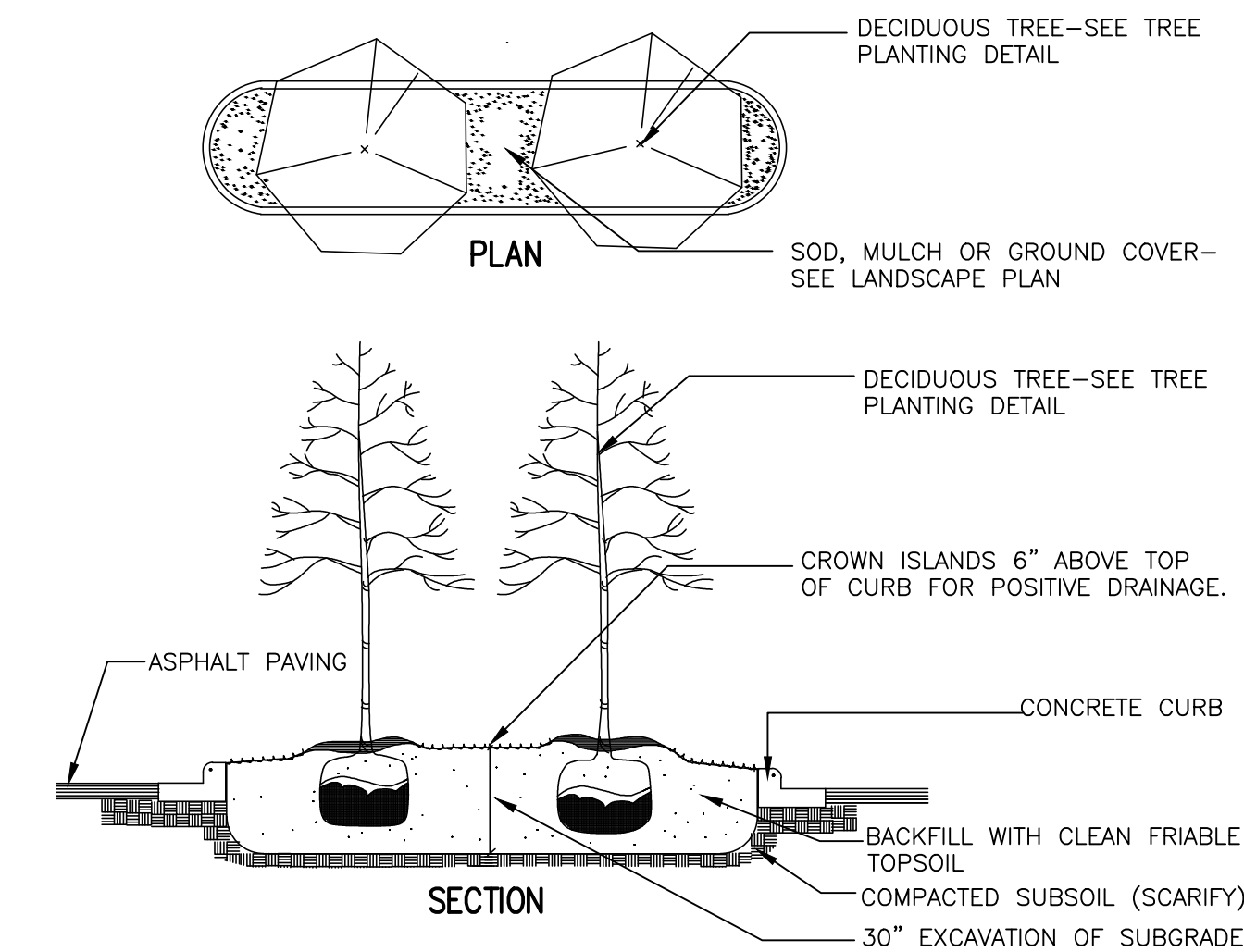

6 TYPICAL ISLAND PLANTING DETAIL
NOT TO SCALE 329343.69-01

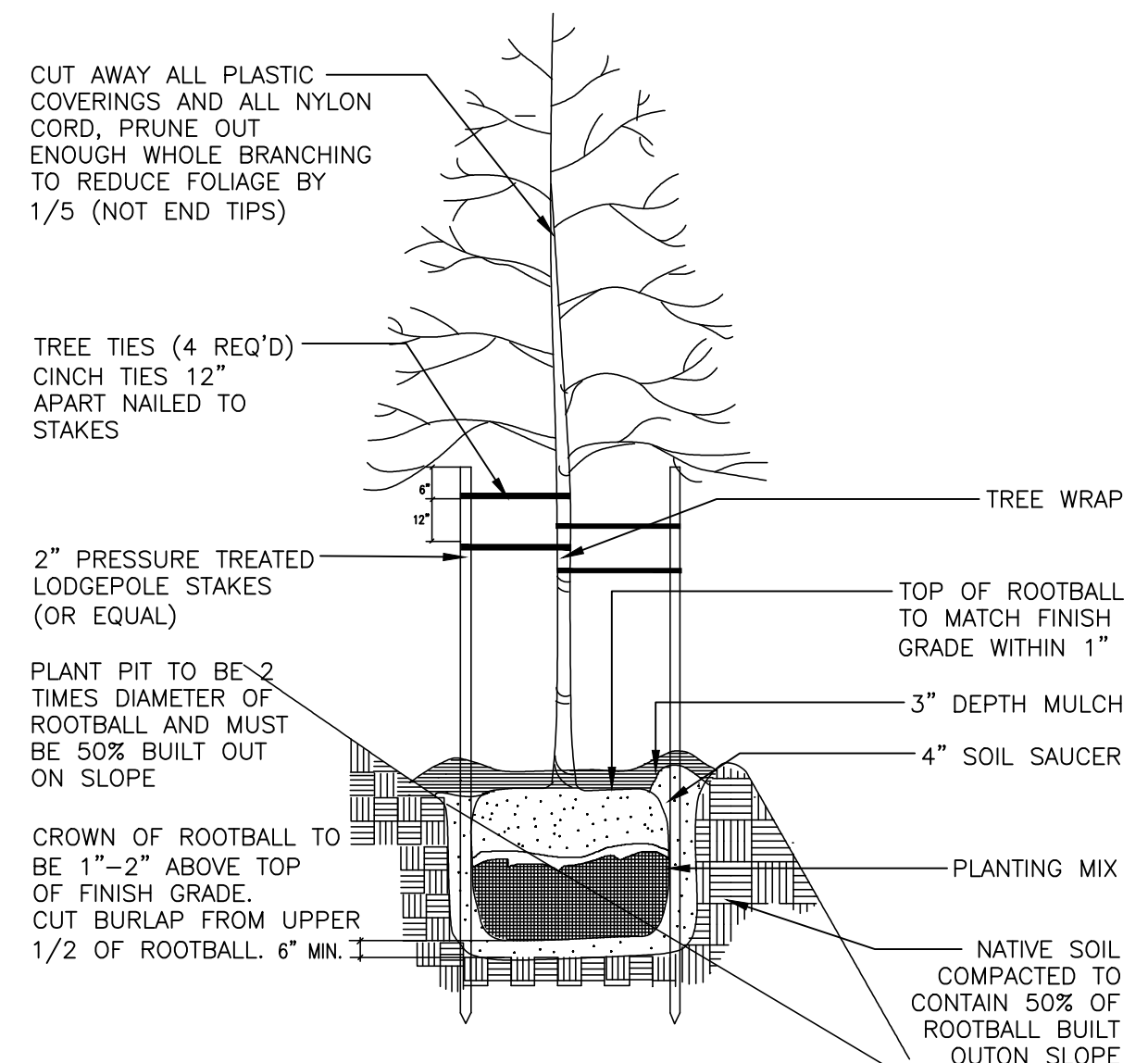

3 TREE PLANTING DETAIL (SLOPE)
NOT TO SCALE 329343.39-02

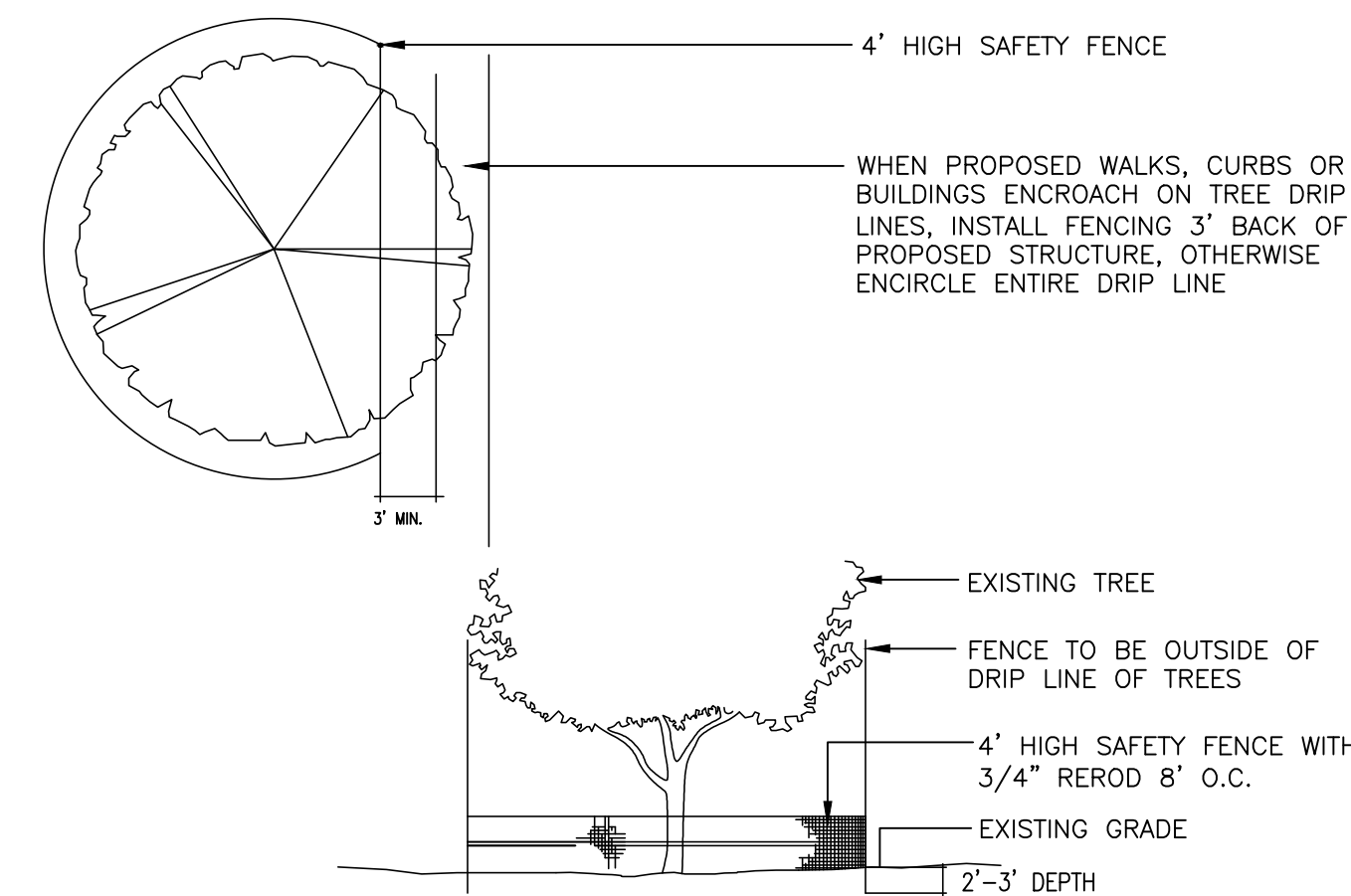

7 TREE PROTECTION DETAIL
NOT TO SCALE 329343.67-01