

NOTES:  
 1) GC TO MAINTAIN CONTINUOUS GAP BETWEEN FRP PANEL TO MATCH KERF CUT  
 2) GC TO USE CONTINUOUS BEAD OF CAULK TO SEAL BETWEEN PANELS - CAULK TO MATCH COLOR OF FRP

**D1 TYPICAL PATTERN FRP DETAIL**  
 Scale: N.T.S.

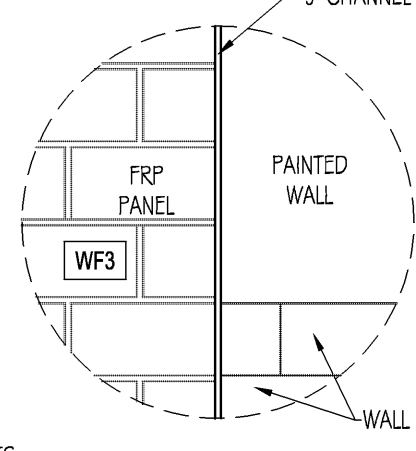

NOTES:  
 1) TILE TO BE HELD TIGHT TO 1/2" CHANNEL TRANSITION  
 2) 1/2" CHANNEL TO MATCH COLOR OF FRP OR STAINLESS STEEL - COORDINATE WITH GOODBA CM

**D2 TYPICAL FRP CAP DETAIL**  
 Scale: N.T.S.

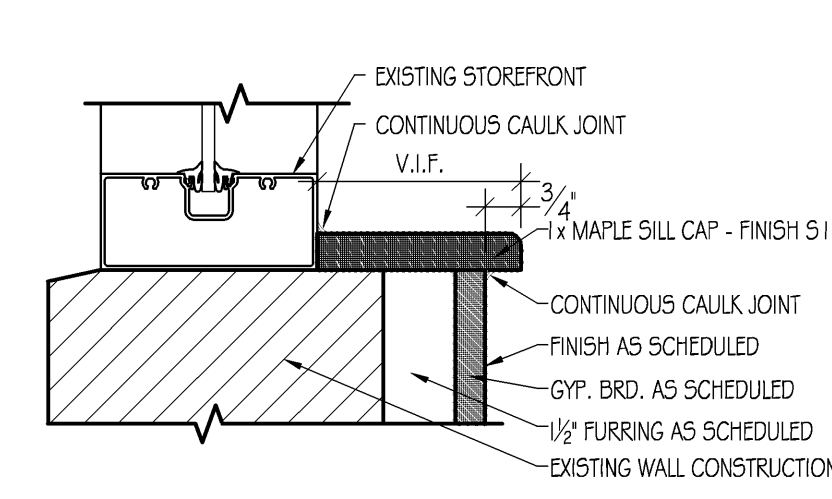

**D3 TYPICAL WINDOW SILL DETAIL**  
 Scale: 3" = 1'-0"

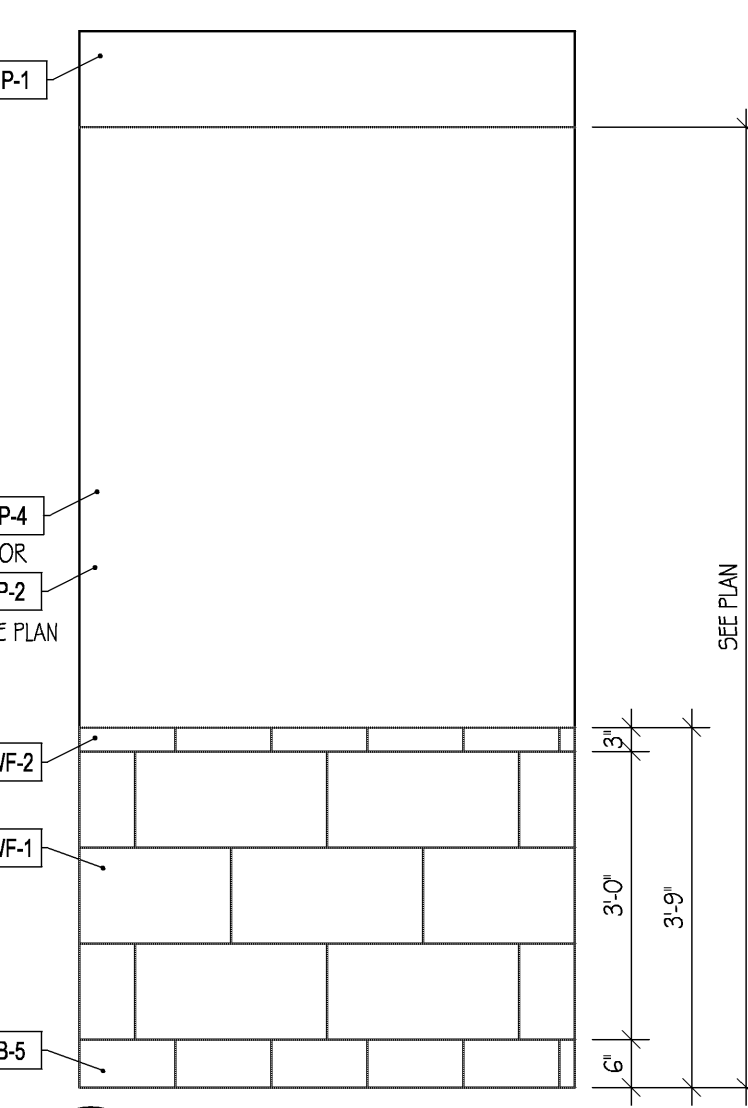

**C1 WALL TILE DETAIL @ DINING**  
 Scale: N.T.S.

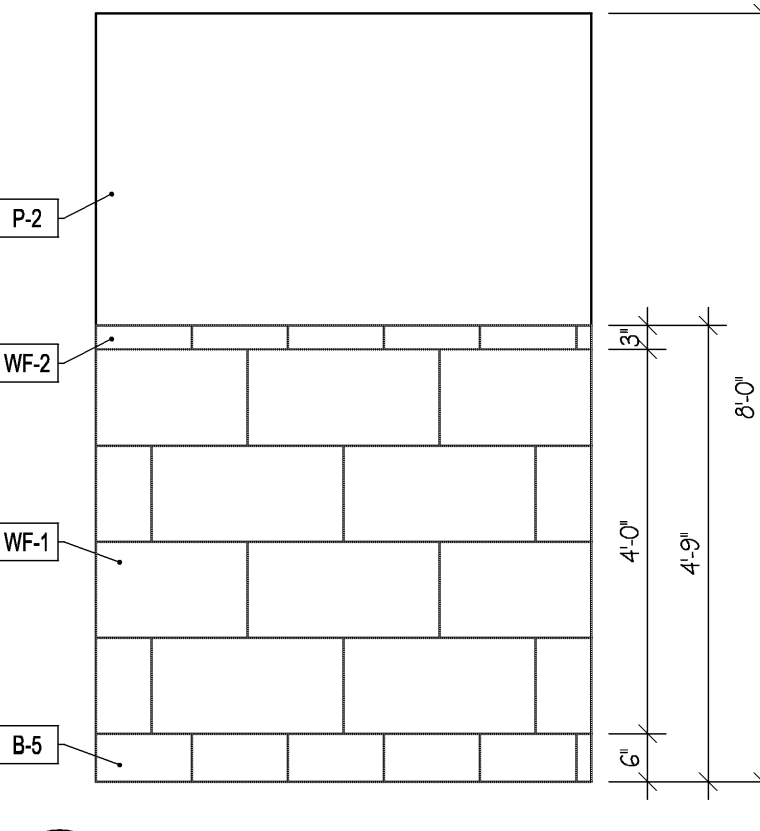

**C2 WALL TILE DETAIL @ RESTROOMS**  
 Scale: N.T.S.

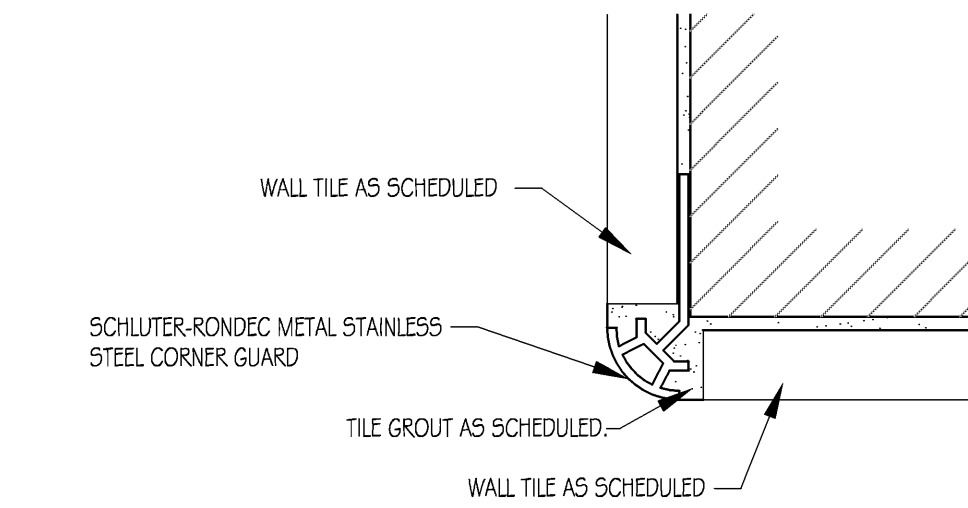

**B3 TYPICAL TILE CORNER DETAIL**  
 Scale: N.T.S.

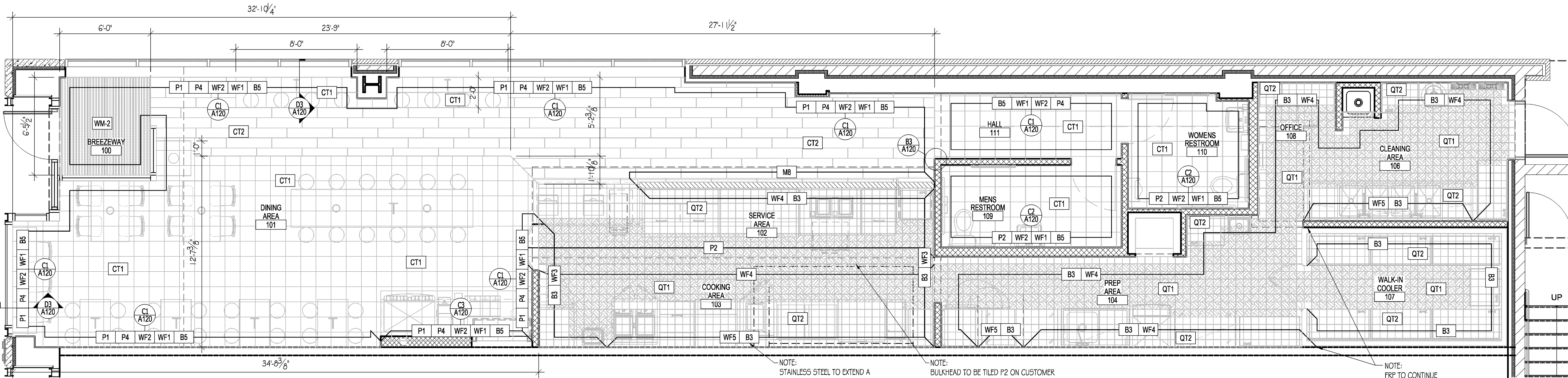

**A120 FINISH PLAN**  
 Scale: 1/4" = 1'-0"

Tag #	Description	Location(s)	Notes
<b>Interior Paints</b>			
P-1	Mfg: Sherwin Williams Material: Latex Paint Color: "High-Tech Black" #SW-1021 L.R.V. 6 Finish: Flat	Location(s): Ceiling & Upper Walls > 10'-0" Above Finished Floor	
P-2	Mfg: Sherwin Williams Material: Latex Paint Color: "Clay Pot" #SW-2917 L.R.V. 1.3 Finish: Satin (Dining Room) Sem Gloss (Restrooms)	Location(s): Menu Board Bulkhead, Accent Wall, Restrooms	If paint area falls within cooking and/or serving area, Pro-classic Oil-based Semi-gloss will be required instead of Satin.
P-3	Mfg: Sherwin Williams Material: Latex Paint Color: "White Hyacinth" #SW-0046 L.R.V. 8.1 Finish: Sem Gloss	Location(s): Service Line Soffit Ceiling, Entry/Vestibule Ceiling, Restroom & Restroom Hallway Ceiling	If paint area falls within cooking and/or serving area, Pro-classic Oil-based Semi-gloss will be required instead of Satin.
P-4	Mfg: Sherwin Williams Material: Latex Paint Color: "Indian White" #SW-0035 L.R.V. 75 Finish: Satin	Location(s): Dining Room Walls	If paint area falls within cooking and/or serving area, Pro-classic Oil-based Semi-gloss will be required instead of Satin.
<b>Base Board</b>			
B-2	Mfg: By Millwork Material: 5-1/2"x3/4" Plastic Trim Base Color: Dark Brown Finish: Plastic	Location(s): Millwork connects to wall	Supplied by Millwork Company
B-3	Mfg: Daltile Material: 6"x6" Textures Series Quarry Tile Cove Base Color: Diablo Red OT01 Smooth Item Number: OT01Q355J1P	Location(s): Cove Base - Kitchen and Food Service Area Price: \$0.95 Each	Grout: Mapei, Grout Color: "Charcoal" #47. Contact: Jennifer Roberts Office (720) 855-3757 & Cell (303) 668-3623 or Brett McLeroy at Dallas Factory #214-398-1411 Or #214-309-3111. Please inform Daltile is product for Qdoba Restaurant.
B-5	Mfg: Crossville Inc. Material: 6"x12" Color Body Cove Base Color: A1114 Tree House Item Number: Color Blox - A1114 Tree House	Location(s): Base where WF-1 occurs Use right and left corners as necessary. \$4.65 a piece. Corner Pieces \$5.60 ea.	Contact: Bob Wiley (800) 999-8453 Cell (303) 910-2733. Please inform item product is for Qdoba Restaurant. Grout: Mapei, Grout Color: "Charcoal" #47
<b>Flooring</b>			
CT-1	Mfg: Daltile Material: 12x12 Terra Antica Porcelain Tile Color: Oro TAO1	Location(s): Dining Room & Restroom Price: \$6/Square Ft. (15 Pieces Per Carton)	Grout: Mapei, Color: "Charcoal" #47. Contact: Jennifer Roberts Office (720) 855-3757 & Cell (303) 668-3623 or Brett McLeroy at Dallas Factory #214-398-1411 Or #214-309-3111. Please inform Daltile is product for Qdoba Restaurant.
CT-2	Mfg: Daltile Material: Color Body Ceramic Tile Color: Cherry FG12 Style: Timber Glen, Bk 24	Location(s): Queuing Line - Price: \$3.88/Square Ft.	Grout: Mapei, Color: "Charcoal" #47. Contact: Jennifer Roberts Office (720) 855-3757 & Cell (303) 668-3623 or Brett McLeroy at Dallas Factory #214-398-1411 Or #214-309-3111. Please inform Daltile is product for Qdoba Restaurant.
QT-1	Mfg: Daltile Material: 6"x6" Textures Series Quarry Tile Color: Diablo Red OT01 Abrasive	Location(s): Kitchen floor/Service Area - Walkways & Accessible Areas Price: \$1.45/Square Foot	Grout: Mapei, Grout Color: "Charcoal" #47. Contact: Jennifer Roberts Office (720) 855-3757 & Cell (303) 668-3623 or Brett McLeroy at Dallas Factory #214-398-1411 Or #214-309-3111. Please inform Daltile is product for Qdoba Restaurant.
QT-2	Mfg: Daltile Material: 6"x6" Textures Series Quarry Tile Color: Diablo Red OT01 Smooth Item Number: Smooth OT01GG1P Smooth	Location(s): Kitchen floor/Service Area - Under Equipment Price: \$1.35/Square Foot	Grout: Mapei, Grout Color: "Charcoal" #47. Contact: Jennifer Roberts Office (720) 855-3757 & Cell (303) 668-3623 or Brett McLeroy at Dallas Factory #214-398-1411 Or #214-309-3111. Please inform Daltile is product for Qdoba Restaurant.
WM-2	Mfg: MATSINC. Material: Entry Carpet Color: Brown Style: Ultra Entry Foot Grille Mfg: Schluter Systems	Location(s): Entrances -	1-800-628-7462 - www.matsinc.com/ProductPage/Products.aspx?style=108 Coordinates installation with mfg. recommendations - Owner provided contractor installed.
TS-1	Mfg: Schluter Systems Material: Tile Termination Strip Color: Aluminum Style: ANIB 80	Location(s): Carpet - Tile Intersection	
TS-2	Mfg: Schluter Systems Material: Tile Termination Strip Color: 304 Stainless Steel	Location(s): Tile to Tile Intersection	

Tag #	Description	Location(s)	Notes
<b>WALL FINISHES</b>			
WF-1	Mfg: American Ocean Material: 12" x 24" Porcelain Tile Color: Creme 5E61 Style: St. German	Location(s): Entry, order line, restroom hallway, restrooms, outer dining walls, community table wall (\$3.30/sf)	Contact: Bob Wiley (800) 999-8453 Cell (303) 910-2733. Please inform item product is for Qdoba Restaurant. Grout: Mapei, Grout Color: "Charcoal" #47
WF-2	Mfg: American Ocean Material: 3" x 12" Bull nose Color: Creme 5E61 Style: St. German - 54369	Location(s): Bulnose to match WF-1 (\$3.30/PC)	Contact: Bob Wiley (800) 999-8453 Cell (303) 910-2733. Please inform item product is for Qdoba Restaurant. Grout: Mapei, Grout Color: "Charcoal" #47
WF-3	Mfg: Maritz Material: 48" x 96" x 3/32" FRP Color: 145 Silver Style: Symmetric, Ashlar Pattern, 3'x6' scoring	Location(s): Order Line back wall	Supplied by Millwork Company - G.C. to use millwork provided sealant for seams between panels
WF-4	Mfg: Kemitec Of Equal Material: Glasbord P with Surfaced (Class C) Color: White #85 - Class "C" Finish: Textured	Location(s): Kitchen - Price: \$1.00/Square Ft. Molding - \$ Standard Molding Price: \$2.25 Ea. 1'0" Standard Molding - Price: \$2.80 Ea.	Contact: Kemitec (800) 435-0080 - Reference Qdoba National Account Pricing.
WF-5	Mfg: Millwork Material: 20 Gauge Stainless Steel Wall Panels Color: Standard Finish: Standard	Location(s): Cook Line Wall and Behind Rice Cooker/Rehmerolizer Wall	Full Height - Supplied and Installed by GC
WF-6	Mfg: 3M Material: Window film Color: "Pearl" Style: Milky 512(MMM)	Location(s): Installed on storefront covered by wall or equipment	G.C. TO PROVIDE AND INSTALL WINDOW FILM PRIOR TO ADJACENT WALL CONSTRUCTION - INSTALLATION RECOMMENDED TO BE DONE BY AN APPROVED WINDOW TINTER
<b>Stain</b>			
S-1	Mfg: Sherwin Williams Material: Varnish Color: "Natural" Finish: Satin Varnish	Location(s): Restroom & Office Doors.	
<b>MISCELLANEOUS</b>			
M-2	Mfg: VestalWall Material: Glasbord P with Surfaced (Class C) Color: #3070 Blank wide stile door Finish: Textured	Location(s): Entry Doors	Contact: Paul Edstrom (303) 994-3021 - Reference Qdoba Mexican Grill Pricing
M-3	Mfg: Bali Blinds Material: Window Blinds Color: 2716 Coffee, Red Cloth Tape Finish: 2" Wood Images Premium Faux Wood	Location(s): Windows	Contact: Cal-Décor, Steve Calhoun (303) 980-9272 Standard Cord Tilt 2"W x 1/8" Thick slats, 9"-96" W, 10"-120" H
M-4	Mfg: Millwork Material: Millwork Color: Clear Finish: Natural	Location(s): Restrooms	Installed to full height of wall
M-6	Mfg: Accurate Partitions Corp Material: Steel Partitions Color: #917 Adalee Finish: Powder Coated	Location(s): Restrooms	Accurate Partitions Corp #708) 442-6800
M-7	Mfg: Millwork Contractor Material: 1-1/2" x 1-1/2" Aluminum Corner Guards Color: Standard Finish: Standard	Location(s): Restrooms	Installed to full height of wall
M-8	Mfg: Millwork Contractor Material: Maple and Stainless Steel Color: Clear Finish: Natural	Location(s): Front of service counter and island wall	Supplied by Millwork Company
M-9	Mfg: Labcrete Material: 9235 and Waterproofing/Anti-Fracture Fabric Color: Clear Finish: Clear	Location(s): At all wet walls & demising wall(s)	Refer to Detail A11A400
M-10	Mfg: Burke Flooring Material: Rouleau Stair Treads Color: #597-Mocha Finish: Un-step Square Profile with abrasive strip	Location(s): At basement stairs and stairs in dining area	See finish plan - A120

NOTE: ALL FINISH MATERIAL SHALL BE A MIN. CLASS B' FLAME SPREAD & SMOKE-DEVELOPED INDEX' CLASS B' FLAME SPREAD 26-75; SMOKE-DEVELOPED Q-450

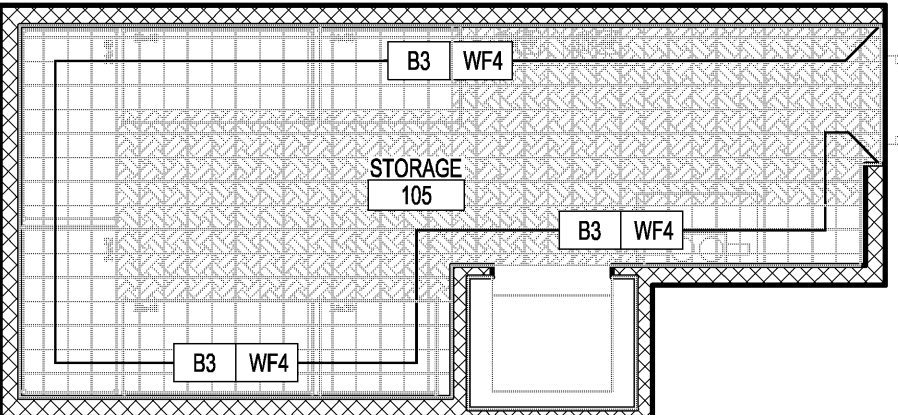

**A120 STORAGE AREA FINISH PLAN**  
 Scale: 1/4" = 1'-0"

- FINISH PLAN NOTES:**
- 1 ALL OUTSIDE CORNERS WITH FRP TO RECEIVE FULL HEIGHT 5.5" CORNER GUARDS UNLESS NOTED OTHERWISE
  - 2 CONTRACTOR TO CAULK BETWEEN FLOOR AND BASE WITH CLEAR SILICON SEALANT.
  - 3 PROVIDE WATERPROOF MEMBRANE UNDER TILE FLOOR MIN. 12" UP WALLS @ RESTROOMS, KITCHEN, DRINK STATION AND DEMISING WALL TYP. (FINISH 1/4" OR EQUAL)
  - 4 SEE PLUMBING AND KITCHEN DRAWINGS FOR QUANTITY AND LOCATIONS OF FLOOR SINKS AND FLOOR DRAINS.
  - 5 ALL CARPET TO TILE FINISH TRANSITION TO RECEIVE TRANSITION STRIP - TS-1

FINISH TYPE	AREA
CT-1	± 445 SQ FT
CT-2	± 265 SQ FT
WM-1	± 39 SQ FT
QT-1	± 441 SQ FT
QT-2	± 354 SQ FT

NOTE: AREAS ABOVE ARE CALCULATED AREAS AND DO NOT ACCOUNT FOR UNIT DIMENSIONS. G.C. TO ADJUST BID TO ACCOUNT FOR UNIT DIMENSIONS.

LINGLEDESIGNGROUP, INC  
 WEST MAIN STREET  
 LENA, IL 61048 158  
 PHONE: 815-369-9155  
 FAX: 815-369-4495  
 WWW.LINGLEDESIGN.COM

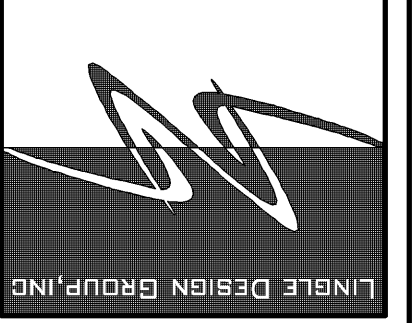

ALL DRAWINGS AND WRITTEN MATERIAL CONTAINED HEREIN ARE THE PROPERTY OF THE ARCHITECT. THEY MAY NOT BE REPRODUCED, COPIED, REUSED, OR DISCLOSED IN ANY MANNER WITHOUT WRITTEN AUTHORIZATION FROM THE ARCHITECT.

**Qdoba MEXICAN GRILL**  
 20 E. Chicago Avenue  
 Chicago, IL 60611-2009

REVISIONS:  
 # DATE: DESCRIPTION:  
 1/8/10 ISSUED FOR PERMIT  
 1/18/10 ISSUED FOR PERMIT

PROJECT NUMBER: 08-118  
 DRAWN BY: SRM  
 CHECKED BY: JTC

SHEET TITLE:  
**FINISH PLAN**

SHEET NUMBER:  
**A120**