

**1 SLOPED FLOOR DRAIN DETAIL**  
P1.2 SCALE: NONE

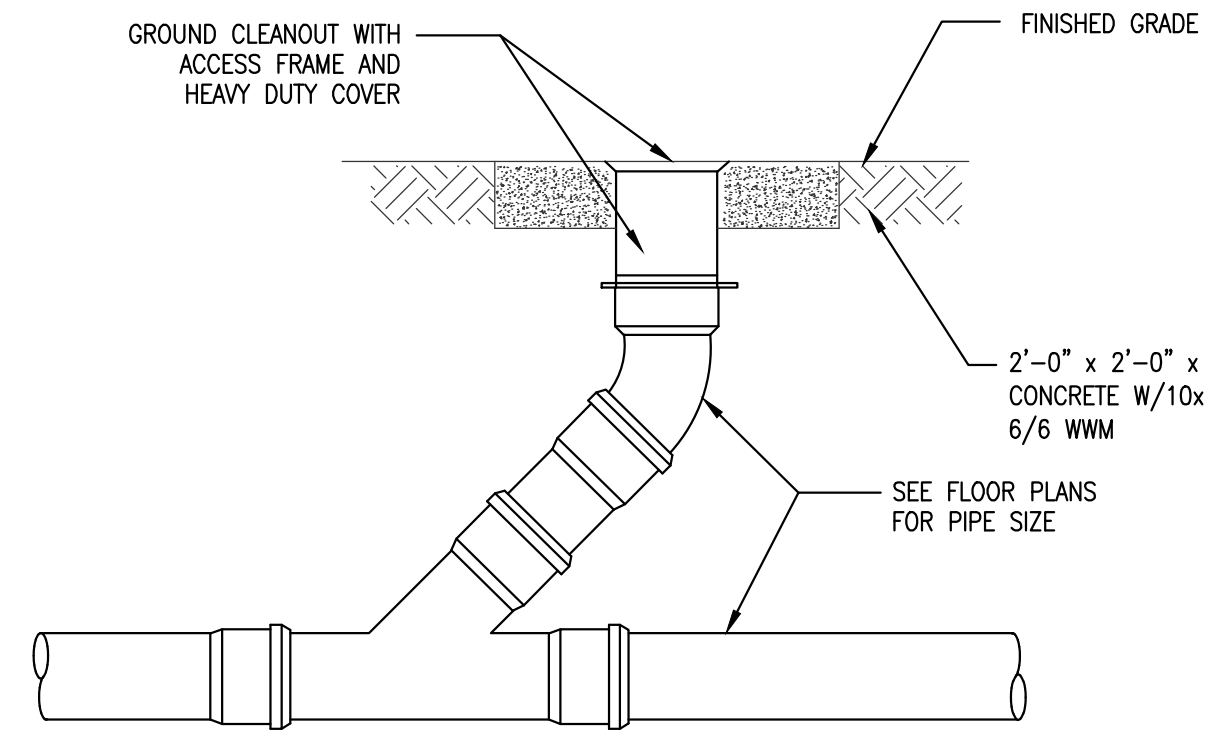

**2 FLOOR CLEANOUT DETAIL**  
P1.1 SCALE: NONE

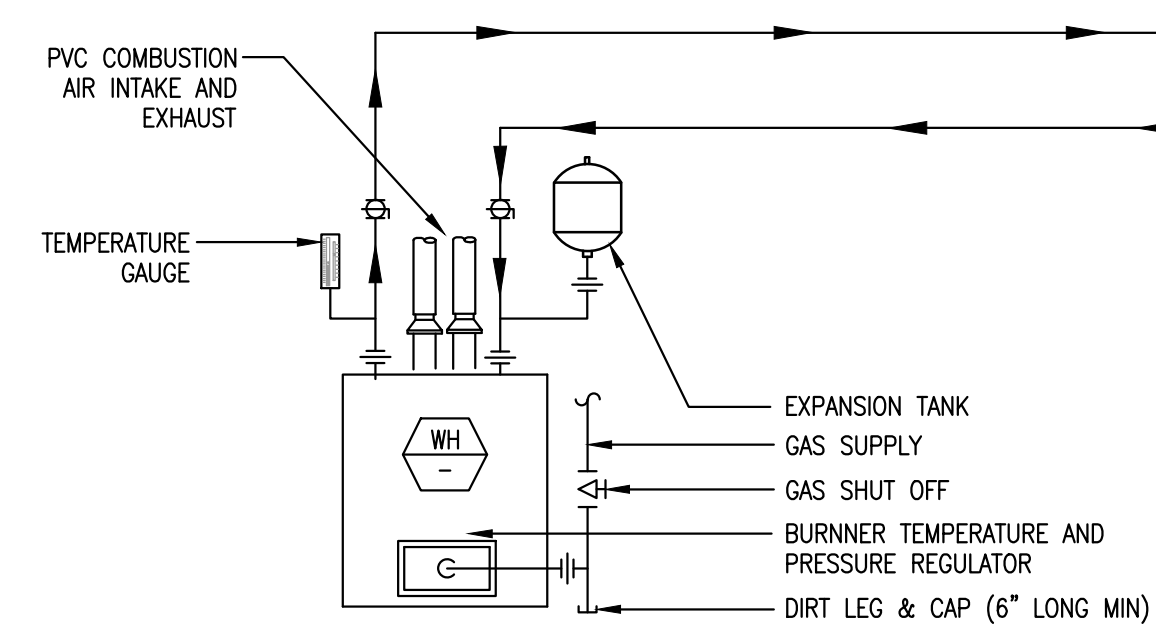

**3 GAS INSTANTANEOUS WATER HEATER DETAIL**  
P1.1 SCALE: NONE

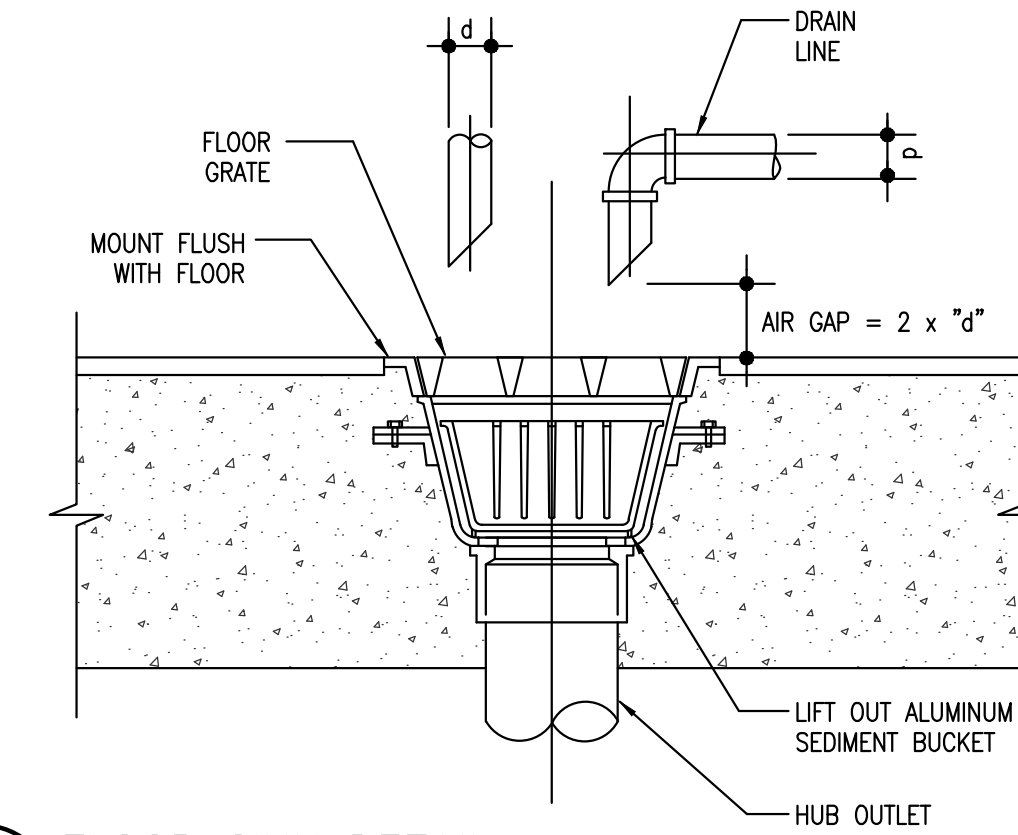

**4 FLOOR SINK DETAIL**  
P1.1 SCALE: NONE

PLUMBING FIXTURE SCHEDULE								
SYMBOL DESIGNATOR	FIXTURE	TYPE	MATERIAL	MANUFACTURER	MODEL NO.	MOUNTING	FAUCET/VALVE	
							MANUFACTURER	MODEL
WC-1	RESTROOM WATER CLOSET ADA	TANK	WHITE VITREOUS CHINA	AMERICAN STANDARD	2998.012	FLOOR MOUNTED	-	-
LAV-1	RESTROOM LAVATORY	-	WHITE VITREOUS CHINA	AMERICAN STANDARD	0124.024	WALL MOUNTED	DELTA	2529-HDF
UR-1	URINAL	FLUSHVALVE	WHITE VITREOUS CHINA	AMERICAN STANDARD	6541.123	WALL HUNG	ROYAL	186-1-YB-YC
MB-1	MOP BASIN	-	MOLDED STONE	FIAT	MSB 2424	FLOOR MOUNTED	FIAT	830-AA

WATER HEATER (WH) SCHEDULE												
EQUIPMENT TAG	LOCATION	ROOM NUMBER	UTILITY SERVICE	TYPE	INPUT HEATING MBH	DELIVERY GPM	DIMENSIONS			ELECTRICAL VOLTS/PH/Hz	MANUFACTURER	MODEL NUMBER
							WIDTH (IN)	HEIGHT (IN)	DEPTH (IN)			
WH-1	STORAGE AREA	105	HW	INSTANTANEOUS GAS FIRED	250	9.3	18.3	24.2	9.4	120/60/1	NORITZ	N-0931M-DV-ASME
WH-2	STORAGE AREA	105	HW	INSTANTANEOUS GAS FIRED	250	9.3	18.3	24.2	9.4	120/60/1	NORITZ	N-0931M-DV-ASME

NOTES:

LINGLEDESIGNGROUP, INC.  
WEST MAIN STREET  
LEVA, IL 61048-1136  
PHONE: 815-369-9155  
FAX: 815-369-4495  
WWW.LINGLEDESIGN.COM



1408 Reed Street, Suite 100  
Naperville, Illinois 60563  
Larson Engineering, Inc.  
LUL. Comm. No. 2-000048-000  
COPYRIGHT © 2010

**Larson Engineering Inc.**

© ALL DRAWINGS AND WRITTEN MATERIAL CONTAINED HEREIN ARE THE PROPERTY OF THE ARCHITECT. THEY MAY NOT BE REPRODUCED, COPIED, REUSED, OR DISCLOSED IN ANY MANNER WITHOUT WRITTEN AUTHORIZATION FROM THE ARCHITECT.



REVISIONS #	DATE	DESCRIPTION
1	07/08/10	ISSUED FOR PERMIT

PROJECT NUMBER: 09-116  
DRAWN BY: LEM  
CHECKED BY: JKN

SHEET TITLE:  
**PLUMBING SCHEDULES & DETAILS**

SHEET NUMBER:  
**P1.1**